



AMIKA 35XL

User & Installation Guide

13.12.2012

All spares available from



The Engine Shed
Top Station Road
Brackley
NN13 7UG
Tel: 0845 1308060
Fax: 01280 845345
Web: www.caterparts.com

Copyright Notice: All rights reserved. No parts of this manual may be reproduced in any form without express written permission of Maidaid-Halcyon (A trading name of Buttress Group Ltd)

CONTENTS

CHAP 1	PREFACE	2
CHAP 2	INSTALLATION	2
2.1	UNPACKING	2
2.2	POSITIONING.....	2
2.3	ELECTRICAL CONNECTION	3
2.4	PLUMBING CONNECTION.....	3
2.5	CONNECTION TO THE DRAIN LINE	4
CHAP 3	RISKS AND IMPORTANT WARNINGS	4
CHAP 4	USING YOUR APPLIANCE.....	5
4.1	SYMBOLS USED.....	5
4.2	STARTING UP.....	5
4.3	LOADING AND WARMING UP	5
4.4	WASHING CYCLE.....	5
4.5	TURNING OFF THE APPLIANCE.....	6
4.6	DISCHARGING THE APPLIANCE.....	7
4.6.1	<i>Models without discharging pump</i>	<i>7</i>
4.6.2	<i>Models with discharging pump</i>	<i>7</i>
4.7	REGENERATING THE ION EXCHANGE RESINS	7
4.8	END OF SERVICE.....	8
CHAP 5	MAINTANANCE.....	8
5.1	HYGIENE AND CLEANING.....	8
5.2	ROUTINE MAINTENANCE (DAILY).....	8
5.3	WEEKLY MAINTENANCE.....	9
5.4	ANNUAL MAINTENANCE	10
CHAP 6	ADJUSTMENTS AND SETTINGS.....	10
6.1	DISPENSER.....	10
6.1.1	<i>Rinse agent dispenser.....</i>	<i>10</i>
6.1.2	<i>Models with no detergent metering unit</i>	<i>11</i>
6.1.3	<i>Models with detergent dispenser (available on request)</i>	<i>11</i>
CHAP 7	DEINSTALLATION	12
CHAP 8	DISPOSAL	12
8.1	CORRECT DISPOSAL OF THIS PRODUCT	12

In legal terms, the manufacturer reserves the property of this document. It is forbidden to reproduce it or divulge it with any means without prior written authorisation.

The manufacturer reserves the right to introduce changes in order to achieve the improvements it deems necessary without prior notice.

Failure to follow the instructions provided in the attached documentation may jeopardize safety of the appliance and immediately cancel the warranty.



The warnings contained in this manual provide important information regarding safety during the various installation, operation and maintenance stages.

Carefully store all documentation near the appliance; give it to the technicians and operators who will be using it. **It is the operator's duty to read, understand and learn this manual before starting any operation on the machine.** The appliance is intended for the professional washing of dishes for communities, so installation, use and maintenance must in all cases to be performed by trained personnel who follow the manufacturer's instructions. Do not leave within the reach of children. The choice of materials, construction in conformity with CE safety directives and complete testing ensure the quality of this machine. In addition to this manual, you will find in the machine:

- wiring diagram
- topographic table

The manufacturer declines all responsibility for damage to things or injuries to persons deriving from failure to comply with the instructions given or from improper use of the machine.

Chap 2 INSTALLATION

Proper installation is essential in order for the machine to operate well. Some of the data needed for machine installation can be found on the data plate placed on the right side of the machine and in duplicate on the cover of this manual.



Only qualified, authorised technicians must install the machine.

For Australia and New Zealand this machine must be installed in accordance with AS/NZS3500.1

2.1 Unpacking

Check that the packing is in perfect condition and write down any damage found on the delivery note. After you have removed the packing, **make sure the appliance is intact.** If the machine is damaged, immediately notify the dealer by fax or by registered letter with advice of receipt and the haulage contractor that transported it. If the damage is such as to jeopardize machine safety, do not install and/or use until a qualified technician services it.



The packing components (plastic bags, foam polystyrene, nails, etc. ...) must not be left within the reach of children and pets as they may be dangerous.

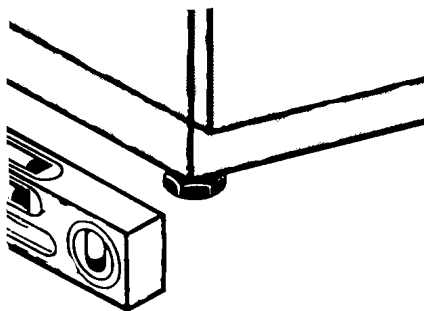

2.2 Positioning

- Check that there are no objects and materials in the installation area that can be damaged by steam that may exit the machine during operation, or at least that they are sufficiently protected.
- In order to ensure stability, install and balance the machine on its four feet.
- Different installation solutions must be agreed upon and approved by the manufacturer.

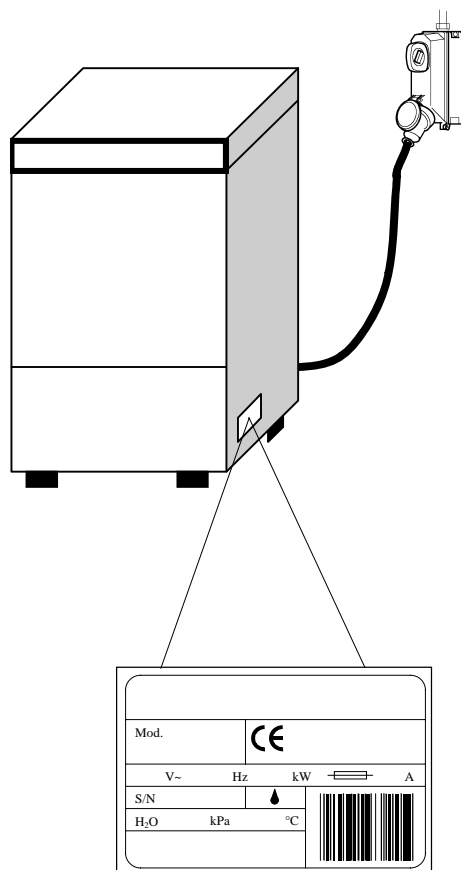

2.3 Electrical connection

- **There must be an omnipolar type of main switch that disconnects all contacts, including the neutral, with a distance of at least 3 mm between the open contacts and with safety circuit breaker tripping or connected with fuses**, to be sized or calibrated in conformity with the power indicated on the machine's data plate.
- The main switch must be located on the electric line close to the installation, and it must serve only one appliance at a time.
- Electric network voltage and frequency must coincide with those given on the data plate.
- There must be an effective earthing system in conformity with the prevention standards in force for operator and equipment safety.
- The power supply cable (type H07RN-F only) must not be pulled or crushed during normal operation or routine maintenance.
- The unipotential terminal fastened to the body must be connected to a unipotential cable having a section suited to the application.
- **Respect the polarities indicated in the wiring diagram.**
- Consult that attached wiring diagram for additional information.



Do not use adaptors, multiple socket-outlets or cables of inadequate type and section or with extension connections not compliant with plant engineering standards in force.

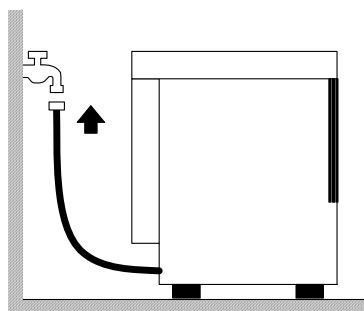

2.4 Plumbing connection

The appliance is to be connected to the water network with a hose. There must be a slide on-off, ball or gate valve **able to quickly and completely turn off the water if necessary** between the water network and the appliance's solenoid valve. The on-off valve must be on the line near and right before the appliance.

- If the system is new or barely used, have the water run a long time before making the connection.
- The water supply, temperature and pressure **must be compatible** with what is indicated on the machine's technical data plate.
- If the water's hardness is greater than 14 F (8 dH), we recommend you use the machine with internal water softener (available on request). If the water's hardness is greater than 35 F (19.5 dH), we recommend you install an external water softener upline of the solenoid valve.

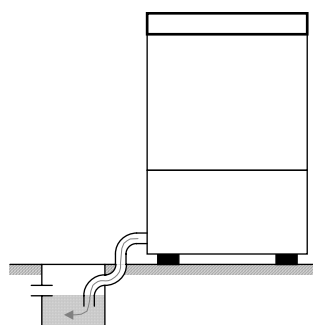

Free drain

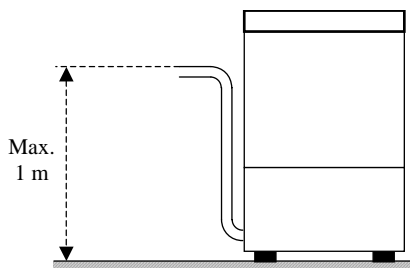
With discharge pump (available on request)

2.5 Connection to the drain line

- **The drain line must be made up of a free water trap** of a size proportionate to the delivery of the drain pipe supplied with the machine. The pipe must be able to reach the water trap **without being pulled, squeezed, bent, crushed, pressed or forced by anything**.
- The tank empties by gravity, so the drain must be at a **lower level than the base machine**.
- If the drain is not at a lower level than the base of the machine, you can use the version equipped with a discharge pump (available on request).
- In this case the maximum drain height is 1 m.
- Always check that the drain works properly and that it is not clogged.
- All other solutions must be previously agreed upon and approved by the manufacturer.

Chap 3 RISKS AND IMPORTANT WARNINGS

- This appliance is to be used only for the use for which it was expressly designed. All other uses are to be considered unfit and therefore dangerous.
- **The specialised personnel who will install the machine is obliged to appropriately instruct the user on the appliance's operation and any safety measures that are to be complied with, also by providing practical demonstrations.**
- Any type of service done on the machine, also in the case of failure, must be performed only by the manufacturer or by an authorised service centre and by qualified personnel, **using only original spare parts**.
- Always disconnect or separate the machine from the electric and water networks before performing maintenance, repairs or cleaning.
- Untrained personnel must **NOT** use the machine.
- The machine must **NOT** remain live when it is not used.
- **NEVER** open the machine door quickly if it has not finished the cycle.
- **NEVER** use the machine without the factory-installed safety attachments.
- **NEVER** use the machine for washing object of a type, shape, size or material not guaranteed for machine washing or not perfectly intact.
- **NEVER** use the appliance or its parts as a ladder or support for people, things or animals.
- **NEVER** overload the open door of front-loading machines, which are sized to support only the rack loaded with kitchenware.
- **NEVER** immerse bare hands in the washing solutions.
- **NEVER** turn the machine over after installation.

Chap 4 USING YOUR APPLIANCE

4.1 Symbols used

	Push the button corresponding to one of the symbols shown.
	The warning light corresponding to one of the symbols shown lights up.

	Push the button corresponding to one of the symbols shown. The related warning light illuminates.
	The warning light corresponding to one of the symbols shown turns off.

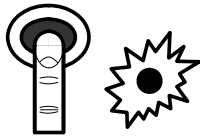

4.2 Starting Up

1. Open the main water tap and engage the main electrical switch.
2. Ensure the overflow cap is present.
3. Push the “on/off” button shown here. If present, the related warning light will light up.

4.3 Loading and Warming Up

- If the tank is empty, the appliance starts filling up once switched on.
- Once the tank is filled up, the warm up process is started. If present, the related warning light goes off.
- As tank and boiler reach the set temperature, the warning light turns off.
- To reduce the waiting time, it is possible to carry out an empty cycle, 5-10 minutes after starting the appliance.

4.4 Washing Cycle

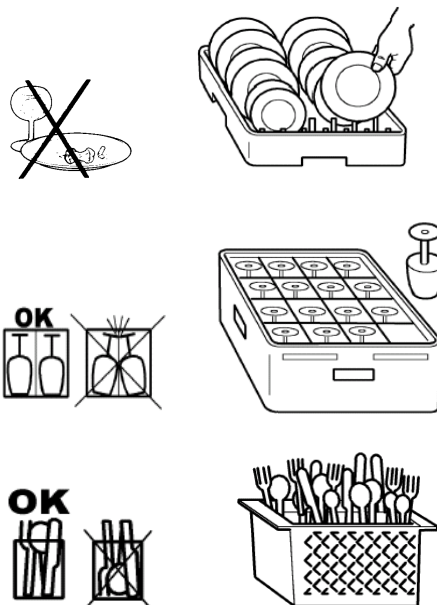

- Check for the presence of dishwashing detergent and rinse agent. Information on the type of products and quantities to be used (automatic or manual) is given in chapter “Adjustments and settings”.
- Use an adequate rack; do not overload the rack or place dishes on top of each other. **Always remove large food particles from dishes**; do not load dishes with dry food residues.
- Place empty bowls upside down in rack. Load dishes and similar items slanted on dedicated rack with internal surface facing upwards. Accommodate all silverware in the supplied basket with handles-down.
- **Wash only items approved for dishwashing.**
- It is advisable to wash the dishes immediately after use, in order to prevent any residuals from hardening and sticking on them.

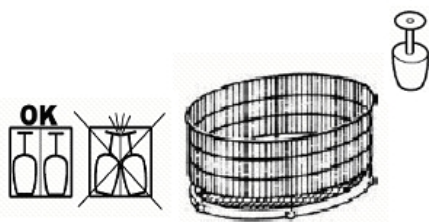
**For versions with rotating basket:**

- If possible, run the cycle only with the basket full, evenly distributing the dishes.
- Place the lightest dishes near the middle of the rack, and the heaviest ones near the outside.
- Place the smallest dishes near the middle of the rack, and the largest ones near the outside.

- Load rack into dishwasher and shut the door.
- **For versions with rotating basket, make sure the basket turns freely, lightly spinning it clockwise, then close the door and start the cycle.**
- In order to avoid damages, only load items approved for dishwashing.
- Do not place silver and stainless steel cutlery in the same basket. This may corrode the steel and cause the silver to burnish.



On appliances featuring different washing times, select the appropriate time for the loaded items by using the “time selection” knob shown here.



- To start the cycle, press the “start” button shown.
- If available, the “cycle warning light” lights up to indicate that the cycle has started.
- After the washing portion of the cycle is terminated, the appliance automatically initiates the rinse and discharge operations. At the end of the cycle, the warning light turns off.

- If during the cycle the door is accidentally opened, the appliance will automatically stop. To resume the cycle, simply shut the door.
- For a quick drying, immediately remove the rack from the dishwasher, once the cycle is terminated.
- **If the washing solution is found to be excessively dirty or dirt residues are spotted on the tank filter, carry out the standard maintenance operations as described in the “Maintenance” chapter.**
- **To perform other cycles, repeat the operations listed in the “Washing cycle” paragraph.**



4.5 Turning Off the Appliance

Press the “On/off” button as shown. If present, the corresponding warning light will turn off.

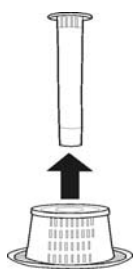

4.6 Discharging the Appliance

4.6.1 Models without discharging pump

1. Turn off the appliance as described in the “Turning off the Appliance” paragraph, above.
2. Remove the overflow cap: wait until the tank is completely empty.

4.6.2 Models with discharging pump

1. Turn off the appliance as described in the “Turning off the Appliance” paragraph, above.
2. Remove the overflow cap and shut the door.
3. Push the “discharging pump” button shown to drain.
4. On models without the “discharging pump button”, turn off the appliance as described in the “Turning off the Appliance” paragraph, above.
5. Remove the overflow cap and shut the door.
6. Push the “start” button, shown to drain.

- With the tank completely empty, clean the appliance as described in the “Maintenance” paragraph.
- Turn off the appliance whenever the overflow cap is removed.

4.7 Regenerating the Ion Exchange Resins

If the machine is equipped with an internal softener (available on request), in order to ensure its correct performance, it is necessary to periodically regenerate the ion exchange resins. The number of cycles between each regeneration is set by the hardness of the water, according to the following table.

dH	F	No. of Cycles
6,0	10	153
6,5	11	147
7,0	12	140
7,5	13	133
8,0	14	127
8,5	15	120
9,0	16	113

dH	F	No. of Cycles
9,5	17	107
10,0	18	100
10,5	19	93
11,0	20	87
12,0	21	83
12,5	22	80
13,0	23	77

dH	F	No. of Cycles
13,5	24	73
14,0	25	70
14,5	26	67
15,0	27	63
15,5	28	60
16,0	29	57
17,0	30	53

dH	F	No. of Cycles
17,5	31	52
18,0	32	50
18,5	33	48
19,0	34	47
19,5	35	43

- It is suggested to carry out the regeneration during breaks.
- Turn off the appliance as indicated in paragraph “Turning off the appliance”.
- Drain the appliance as indicated in paragraph “Discharging the appliance”.
- Clean the dishwasher as directed in chapter “Maintenance”. At the end of the cleaning procedure, open the main water tap and engage the main electrical switch.

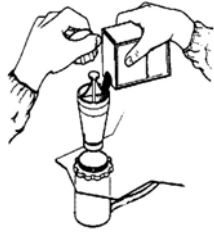

- Make sure the overflow cap has been removed.
- Open the salt dispenser inside the tank.
- Pour approx. 250g of regenerating salt (cooking salt with no additives and grains of 1-2 mm in diameter).
- Close the dispenser flap.
- Shut the door

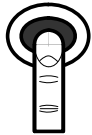

- **Without turning the appliance on**, press the “start” button until the “cycle warning light” goes off.
- The regeneration cycle is then started and will last for approximately 20 minutes.



- The regeneration is completed when the cycle warning light turns off.

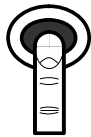

At the end of the regeneration cycle, with the tank empty and the overflow cap removed, it is suggested to:

- Turn the appliance on by pressing the “On/off” button shown.
- Let water run through for approx. 1 minute so to remove salt residues from the tank.
- Turn the appliance off by pressing the “On/off” button; hence refit the overflow cap.

The appliance is now ready to resume its service.

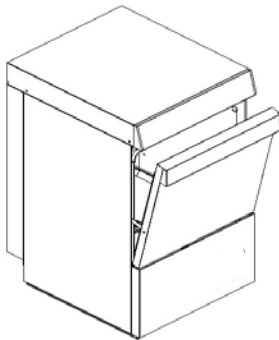

4.8 End of Service

- At the end of the day always drain the machine as described in the “Machine draining” section.
- **Disconnect the power supply by means of the main switch and close the external water cock.**
- Perform routine maintenance and clean the machine as described in the “Maintenance” section.
- If possible, leave the door ajar to prevent the formation of bad smells inside.

Chap 5 MAINTANANCE



Before carrying out any maintenance operation, drain all the water as described in paragraph “Discharging the Appliance”, cut the power by disengaging the main electric switch, and shut the external water valve.

5.1 Hygiene and cleaning

To guarantee machine hygiene **the routine (daily), weekly and yearly maintenance operations** indicated below must be regularly performed. Also carry out a periodical sanitising treatment with suitable non-corrosive products available on the market.

5.2 Routine maintenance (daily)

- If dirt residues are found at the bottom of the tank:
- Remove and clean racks, overflow, and filter.

- To clean the steel tank, do not use abrasive detergents or objects; instead, use a lightly soaped damp cloth.
- Do not use pressurised water jets as these may damage the electrical system.

5.3 Weekly Maintenance

- Perform routine maintenance.
- Remove and clean the wash and rinse arms and nozzles.

Illustrated below are the possible configurations of upper and lower wash/rinse arms.

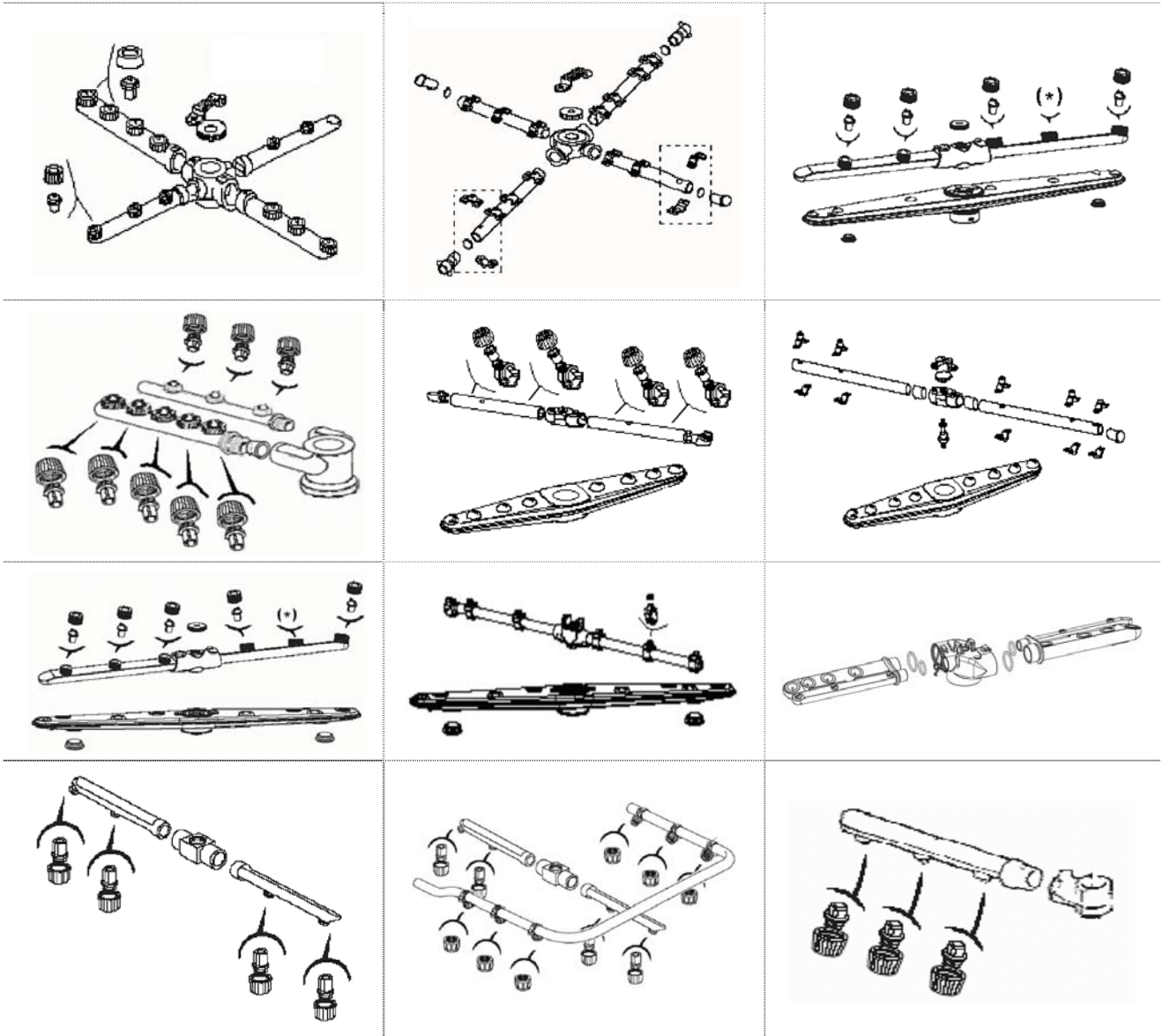

(*) Spray closed. Nozzle not present.

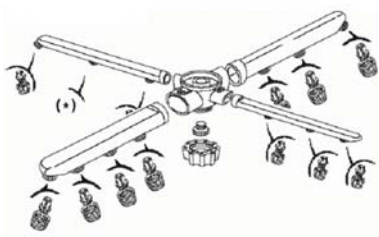

- Clean the arm rotation pins and the wash and rinse water outlet zone.
- Carefully clean the tank and machine, using non-abrasive disinfectant products.
- Correctly refit the nozzles, arms and filters, paying attention to the inclination and coupling of the arms in their respective seats.

Have your appliance carefully inspected by an authorised technician, and in particular:

- Remove residues from the bottom of the tank.
- Remove and deep clean wash arms and diffusers.
- **Thoroughly clean the weir inserted in the lower wash arm shaft and the water exit area.**
- Correctly refit weir, pivoting pins and wash arms.
- Inspect the conditions of the sealing gaskets and the wear of other components such as pumps, dispensers, etc.
- Inspect the settings of washing detergent and rinse agent dispensers.
- Inspect and eventually clean the resistors.

If the appliance is not used for long periods of time, it is necessary to have it adequately setup. If you have any suspects about the presence of ice, do not run the appliance until an authorised technician has inspected boiler and pipes.

Chap 6 ADJUSTMENTS AND SETTINGS

The following adjustment and setting operations may be carried exclusively by qualified and authorised personnel, paying the utmost care and attention, and taking all precautions in the event that safety features are bypassed.

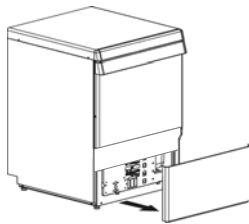

6.1 Dispenser



Before the **zeroing** operation may be carried out, dispenser(s) and supply pipes must be filled up. The zeroing is performed via the adjusting screws which may be reached by removing the front panel underneath the tank door.



- **The warranty does not cover damages resulting from improper use of the dispenser(s) or incorrect manual feed.**
- **Type and dosage of detergent and rinse agent are crucial in affecting the appliance's performance and service life. Use only liquid products for industrial washing with antifoaming agents.**
- **Adjustments must be made with the appliance hot and correct amount of washing product.**



6.1.1 Rinse agent dispenser

The level of rinse agent inside the container must be adequate; it must never be completely emptied, or topped-up with corrosive or impure products. To fill up the supply pipe and the dispenser, turn on the appliance and start the washing cycle, wait for approx. 20 seconds and press the "On/off" button  /  for 8-10 times with intervals of approximately 10 seconds. Leave it pressed to let the cycle terminate.

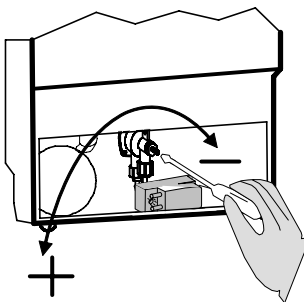

- Turning the adjusting screw anticlockwise, reduces the quantity of rinse agent released, while turning it clockwise, increases the dosage.
 - For a rough estimate concerning the amount of rinse agent required for the first zeroing operation, refer to the dosage suggested by the manufacturer of the product.
 - The screw adjustment must be refined on the basis of the results obtained after at least three rinsing cycles, so to let the system settle.
- Striations on washed items and the formation of foam within the washing solution indicate an excessive quantity of rinse agent. Items covered with water drops and long drying time, indicate

insufficient amount of rinse agent.

- To obtain optimum results, use only rinse agents with a manufacturer's suggested dosage of less than 1.5 gr. /litre.
- 7.9 cm of pipe = 1 ml. of product (= 1 gr. of product with a density of 1 kg/dm³). The amount of water used for the rinsing process is approx. 3 litres/cycle.
- Do not modify the height difference between tank and appliance after setting the dosage.
- If the height difference between tank and base of appliance is more than 80 cm, the dispenser may not work correctly.
- If rinse aid is not used, completely close the dispenser adjustment screw.

6.1.2 Models with no detergent metering unit

Manual feed is discouraged as it does not guarantee the optimal results offered by an automatic system. If, however, an automatic dispenser is not used, introduce the detergent in the pump intake filter area every five cycles, in the dosage suggested by the manufacturer of the detergent. Refer to the technical specifications to find out the amount of water used in the tank; the quantity used for rinsing is approx. 3 litres. At every top-up, add a quantity of detergent corresponding to the quantity of water in the tank and the five following rinsing cycles. For following dosages only add the amount of detergent required for rinsing operations.

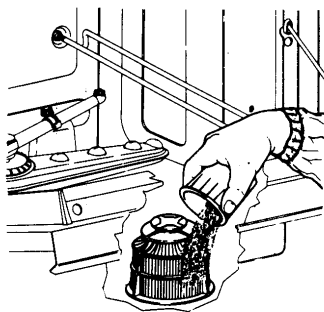

The installation of a detergent dispenser is always recommended.

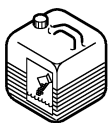

6.1.3 Models with detergent dispenser (available on request)

The level of detergent inside the container must be adequate; it must never be completely emptied, or topped-up with corrosive or impure products. To fill up the supply pipe it is sufficient to turn on the appliance and perform the first loading with the unit connected.

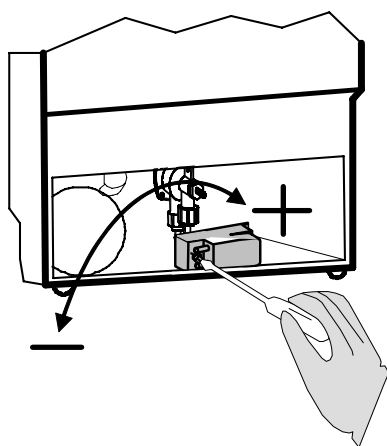

- Turning the adjusting screw anticlockwise decreases the amount of detergent released, while turning it clockwise, increases the dosage (from 1 to 1.5 ml per rinse per mark, corresponding to approx. 1.2 – 1.8 gr. of product with density 1.2 kg/dm³). Check the appliance's technical specifications to find out about the amount of water in the tank.
- For a rough estimate concerning the amount of rinse agent required for the first zeroing operation, refer to the dosage suggested by the manufacturer of the product.
- The screw adjustment must be refined on the basis of the results obtained after at least three rinsing cycles, so to let the system settle.

- **At the end each cycle, no foam must be present in the tank.**
- If foam is present, first check the type of detergent used and eventually replace with a more adequate one. If foam is still present, check the water temperature in the tank is correct and eventually reduce the dosage of detergent until all foam is successfully eliminated.
- With the dispensers supplied, it is necessary to use only detergent with a manufacturer's suggested dosage less than 5 gr. /litre.

Chap 7 DEINSTALLATION



Only qualified and authorised technical personnel can perform deinstallation.

- **Turn off the power to the machine with the external main switch.**
 - **Shut off the external water supply tap.**
 - **Completely disconnect the machine from the electric and water supply networks.**
 - Empty, clean and completely prepare all the internal water circuits, measuring devices, pumps and boiler.
 - Completely empty the detergent and rinse aid dispensers and tubes connected to them, making sure to correctly dispose of the detergent and rinse aid (contact the supplier of the products used)
-

Chap 8 DISPOSAL

There are no materials on our machines that require special disposal procedures.

8.1 Correct Disposal of this product

(Waste Electrical & Electronic Equipment)

(Applicable in European Union and other European countries with separate collection systems)

This marking shown on the product or its literature, indicates that it should not be disposed with other household wastes at the end of its working life. To prevent possible harm to the environment or human from uncontrolled waste disposal. Please separate this from other types of wastes and recycle it responsibly to promote the sustainable reuse of material resources.



Household users should contact either the retailer where they purchased this product or their local government office, for details of where and how they can take this item for environmentally safe recycling.
