



# Wiring diagram

## D515WS

All spares available from



The Engine Shed  
Top Station Road  
Brackley  
NN13 7UG  
Tel: 0845 1308060  
Fax: 01280 845345

**Copyright Notice:** All rights reserved. No parts of this manual may be reproduced in any form without express written permission of Maidaid-Halcyon (A trading name of Buttress Group Ltd)

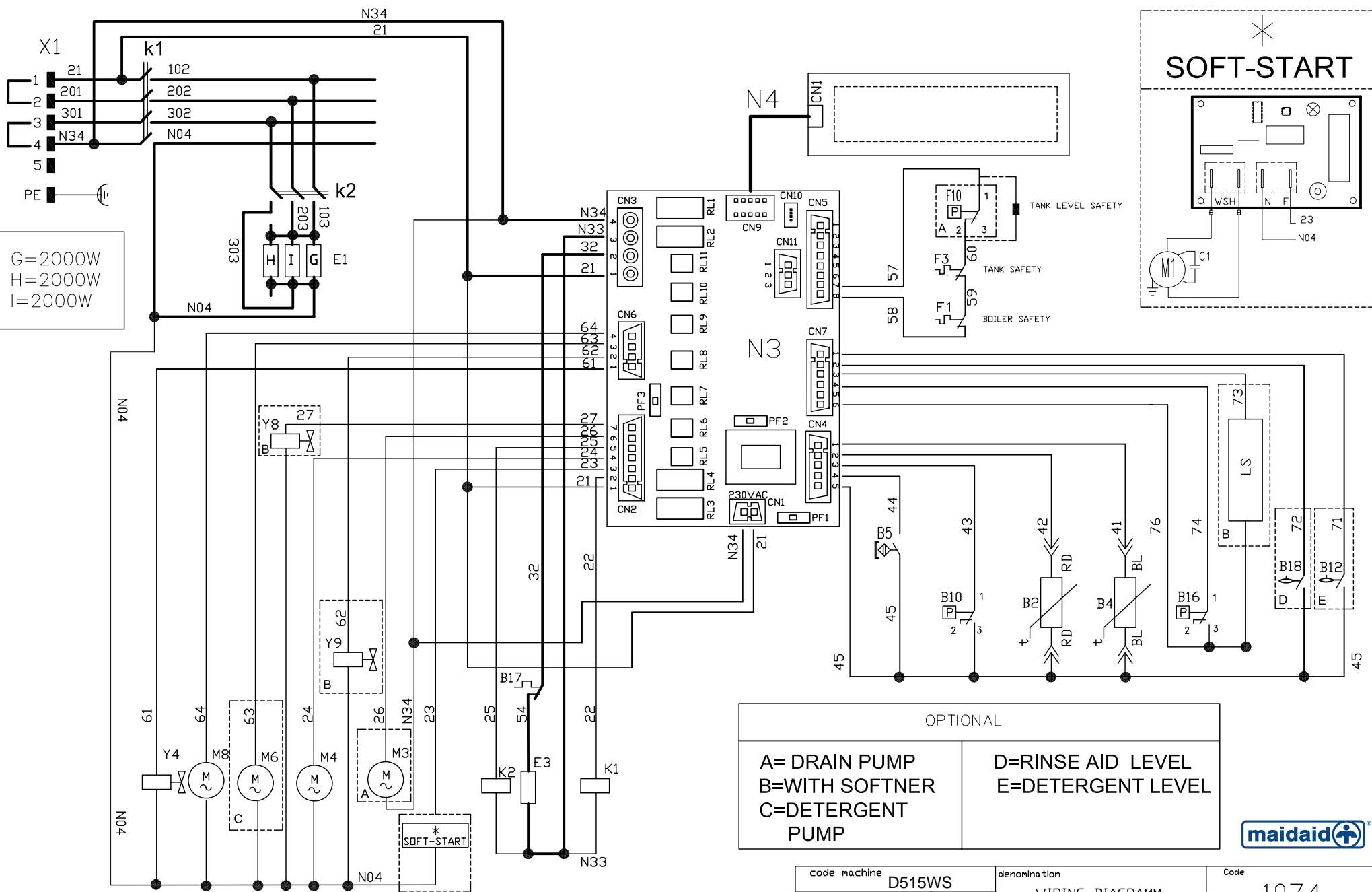

G=2000W  
H=2000W  
I=2000W

OPTIONAL

A= DRAIN PUMP  
B=WITH SOFTNER  
C=DETERGENT PUMP

D=RINSE AID LEVEL  
E=DETERGENT LEVEL



code machine		D515WS		denomination		Code	
re-examined		01/02/13		WIRING DIAGRAM		1074	
inspected by		date		From S/N 2750144		n°/file	
Bertolini		01/02/13		total blat		mod	
validated by		01/02/13		4		1074	
				N°blat		-3	
				Next blat			

n° MODIFICA	DESCRIZIONE	SOSTITUISCE	DATA
-3	Cambiata posizione neutri su conversioni.	1074-2	04/11/09

230v 1N 50hz 6,6kw 30A

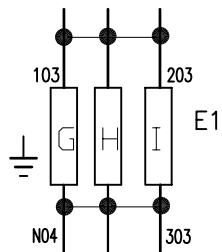
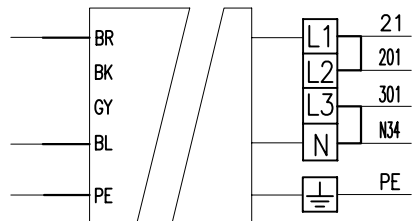
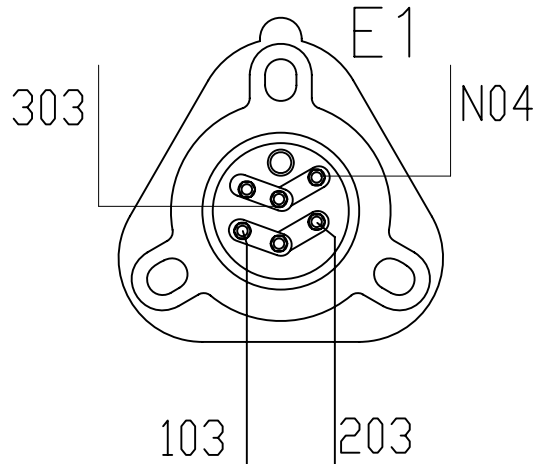

230v 1N 50hz 4,6kw 20A

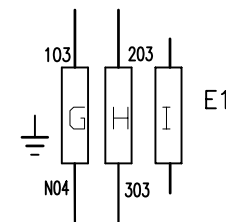
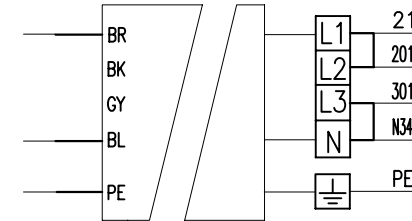
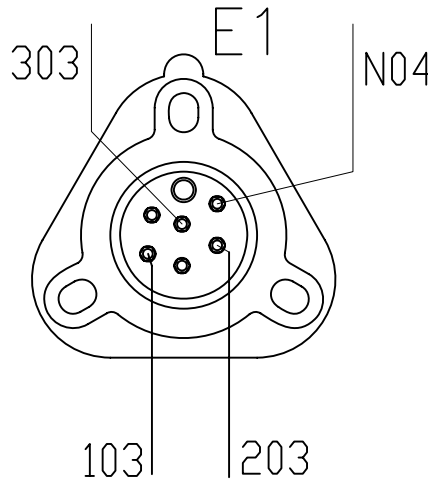

400v 3N 50hz 6.6kw 16A

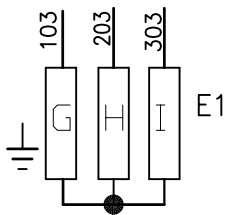
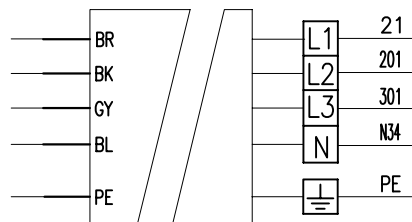
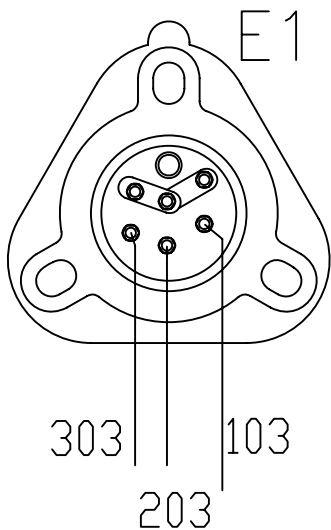

230v 1N 50hz 2,6kw 13A

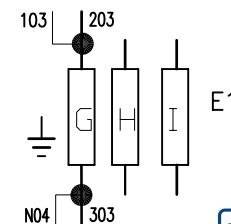
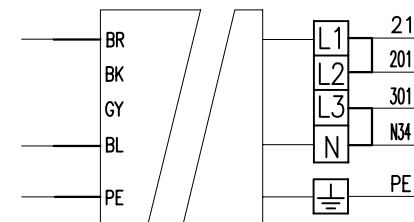
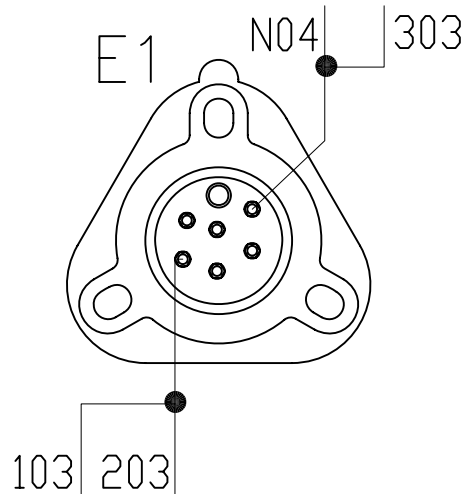

G=2000W  
H=2000W  
I=2000W

code machine D515WS

denomination WIRING DIAGRAM

Code 1074

re-examined date 01/02/13

inspected by Bertolini date

From S/N 2750144

n°/file nod

validated by date 01/02/13

total blat 4 N° blat 2 Next blat -

1074a -3

DESCRIZIONE

SOSTITUISCE

DATA

-3  
-2

**FRONT**

**REAR**

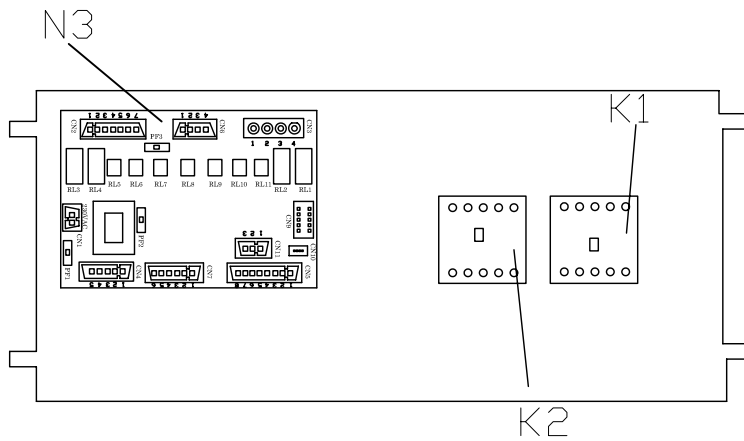
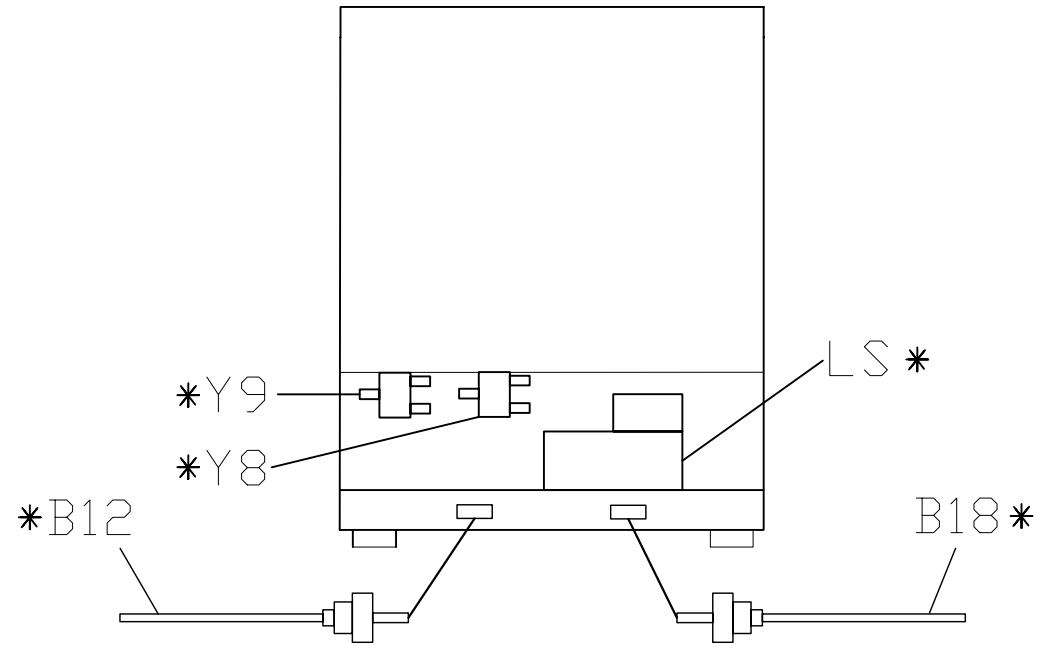
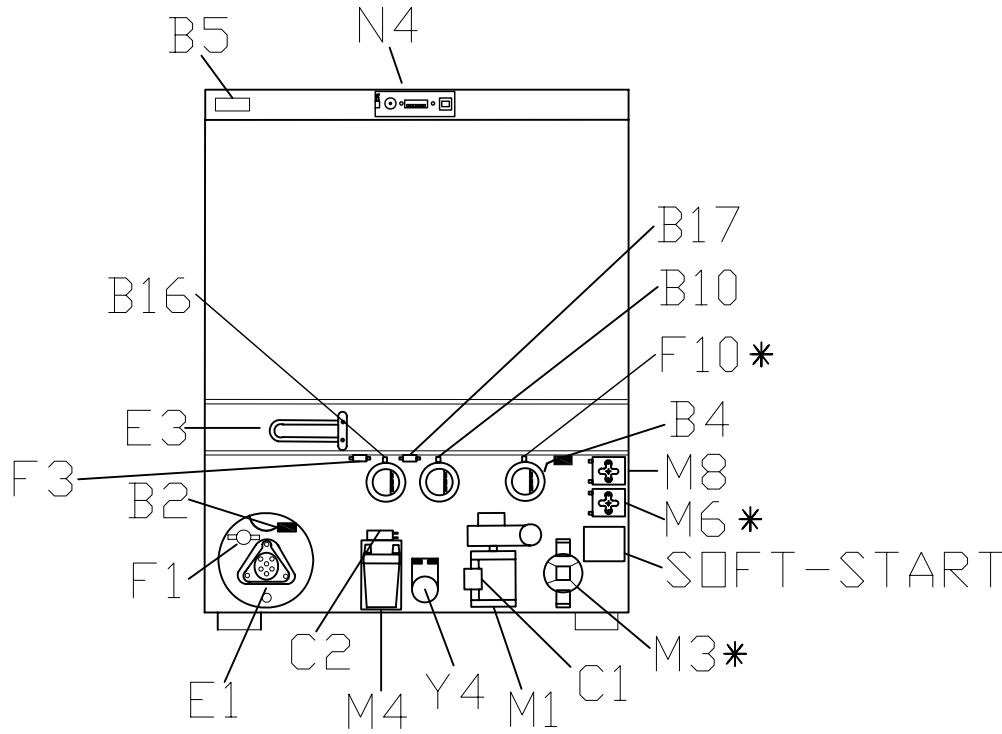

\* **OPTIONAL**



code <b>D515WS</b>		denomination <b>TOPOGRAPHICAL</b>			Code <b>1074</b>	
re-examined	date <b>01/02/13</b>	dishwasher			n°/file	mod
inspected by <b>Bertolini</b>		total blat <b>4</b>	N°blat <b>3</b>	Next blat <b>-</b>	<b>1074T</b>	<b>-3</b>
validated by	date <b>01/02/13</b>					

n° MODIFICA	DESCRIZIONE	SOSTITUISCE	DATA
-1			
-2			

	GB	D	F	I	E	P
B2	Boiler probe	Temperaturfühler Durchlauferhitzer	Sonde surchauffeur	Sonda boiler	Palpador de temperatura calderin	Sonda de temperatura caldera
B4	Tank probe	Tanktemperaturefühler	Sonde cuve	Sonda vasca	Palpador de temperatura en la cuba	Sonda de temperatura tanque
B5	Door switch	Reed- Türsicherheitkontaktschalter	Micro contact de porte	Micro porta	Interruptor de puerta	Micro-interruptor porta
B7	Filter switch	Filterkontaktschalter	Interrupteur de filtre	Microcontatto filtro	Interruptor del filtro	Micro-interruptor filtro
B10	Tank level control	Tankniveauschalter	Pressostat de cuve	Controllo livello vasca	Interruptor del nivel en la cuba	Interruptor de nivel tanque
B12	Detergent level	Spülmittelniveauschalter	Contrôle niveau déterergent	Controllo livello detergente	Comprobación de nivel detergente	Interruptor de nivel detergente
B16	Booster level control	Nachspülboiler Niveauschalter	Pressostat niveau surchauffeur	Controllo livello boiler	Control nivel calderin	interruptor de nivel do boiler
B17	Tank limiting thermostat	Tank begrenzung thermostat	Thermostat de limitation de la cuve	Termostato limitatore vasca	Termostato limitador cuba	Limitador de temperatura caldera
B18	Rinse aid level	Stufe Glänzmittel	Contrôle niveau produit de rinçage	Controllo livello brillantante	Comprobación de nivel abrillantador	Interruptor de nivel solução para brilho
C1	Wash pump noise filter	Fünkenstörfilter Umwälzpumpe	Condensateur pompe de lavage	Condensatore pompa lavaggio	Condensador bomba de lavado	Condensador bomba lavagem
C2	Rinse booster pump noise filt.	Fünkenstörfilter Drucksteigerungpumpe	Condensateur pompe auxiliaire	Condensatore pompa ausiliaria	Condensador bomba de aumento presión	Condensador bomba do aumento de pressão
E1	Boiler heating element	Heizkörper Durchlauferhitzer	Resistance du surchauffeur	Resistenza boiler	Resistencia del calderin	Resistências caldera
E3	Tank heating element	Tankheizung	Resistance de cuve	Resistenza vasca	Resistencia de la cuba	Resistências cuba
F1	Boiler safety thermostat	Durchlauferhitzer Temperaturbegrenzer	Thermostat securite surchauffeur	Termostato sicurezza boiler	Limitador de temperatura del calderin	Rgolador de temperatura caldera
F3	Tank safety thermostat	Tanktemperaturbegrenzer	Thermostat securite cuve	Termostato sicurezza vasca	Limitador de temperatura del deposito	Rgolador de temperatura tanque
F10	Tank level safety switch	Überlaufschutz Tankniveauschalter	Pressostat de contrôle niveau Cuve	Sicurezza livello vasca	Interruptor de nivel agua en la cuba	Segurança de nivel tanque
K1	Main relay	Relais EIN / AUS	Relais Marche / Arrêt	Relè di linea	Relé suministro de corriente	Relé de alimentação elétrica
K2	Boiler heating element relay	Durchlauferhitzer Heizkörper Relais	Relais resistance surchauffeur	Relè resistenza boiler	Relé resistencia Calderin	Relé de resistência de caldeira
LS	Salt level control	Salz höhe kontrolle	Contrôle niveau de sel	Controllo livello sale	Controlor nivel de sal	Sal nivel controllo
M1	Wash pump motor	Motor Umwälzpumpe	Moteur pompe lavage	Motore pompa lavaggio	Motor bomba lavado	Motor bomba de lavagem
M3	Drain pump motor	Motor Laugenpumpe	Moteur pompe vidange	Motore pompa scarico	Motor bomba de desagüe	Motor bomba de esgoto
M4	Rinse booster pump motor	Motor Drucksteigerungpumpe	Moteur pompe auxiliaire	Motore pompa ausiliaria	Motor bomba para aumentar la presión	Motor bomba de enxague
M6	Detergent pump motor	Dosiergerät Reiniger	Moteur pompe produit lavage	Dosatore detergente	Dosificador por el detergente	Doseador de detergente
M8	Rinse aid pump motor	Dosiergerät Glänzmittel	Moteur pompe produit de rinçage	Dosatore brillantante	Dosificador abrillantador	Doseador da solução para brilho
N3	Electronic control	Programmschaltwerk Elektronikmodul	Carte controle cycle	Scheda controllo ciclo	Electrónica de control ciclo	Módulo electrónico temporizador de ciclo
N4	Auxiliary electronic control	Zusatzelektroplatine	Carte électronique auxiliaire	Scheda controllo ausiliaria	Electrónico de control auxiliar	Placa eletrônica auxiliar
RC	RC-ELEMENTS	RC-GLIED	FILTRE RC	FILTRO RC	FILTRO RC	FILTRO RC
Y4	Fill / hot rinse solenoid valve	Elektromagnetventil Füllen / Klarspülung warm	Electrovanne remplissage	Elettrovalvola carico / risciacquo caldo	Válvula magnética de entrada / enjuague caliente	Válvula magnética de entrada / enxague quente
Y8	Regeneration solenoid switch valve	Regenerieren Elektromagnet wechselventil	Electrovanne échangeur régénération	Elettrovalvola scambiatrice di rigenerazione	Válvula cambiadora de regeneración	Válvula cambista de regeneração
Y9	Regeneration solenoid switch valve	Regenerieren Elektromagnet wechselventil	Electrovanne échangeur régénération	Elettrovalvola scambiatrice di rigenerazione	Válvula cambiadora de regeneración	Válvula cambista de regeneração